

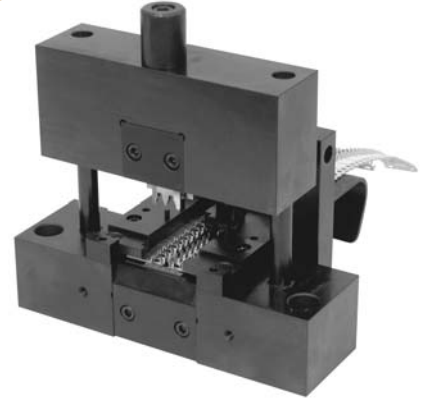

Application Equipment

Standard Applicator

Available for some Heyco® terminals. Fits in standard bench presses with 5" shut height and 1-1/2" stroke. Left-to-right and right-to-left or rear feed.



Universal Assembly Die

Modular design allows the application of a wide variety of terminals in one die set. The top and bottom "tool packs" are replaced to apply different types of terminals. Adjustable feed: left-to-right or right-to-left. Adjustable stroke: fits most standard 3 and 5 ton presses. Easy crimp height adjustments. New feed and drag design make for simple consistent feed adjustments.

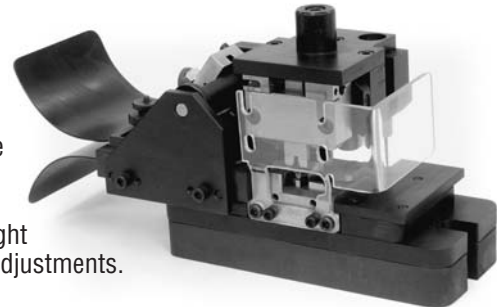

Semi-Automatic Application Systems

This equipment provides accurate, easy termination of all three contacts at once, for Heyco's Male and Female Preassembled Cordset Components. Parts are bowl or gravity fed into the application die eliminating the need for operator placement. The unique funnel design provides precise placement of the wire in the contacts crimps. A Stripping unit can be added to prepare the wire prior to termination.



Wire Stripper

Heyco now offers a Wire Stripping Unit for use with our Standard and Universal applicators and our Semi-Automatic Application Systems. This unit will cut and strip to length the inner jacket of your wire. It also preforms the wire for faster insertion when using our Semi-Automatic Application Systems.

Order the Z464 Wire Stripper Assembly Base with the appropriate wire gage tooling shown:

- Z462 Wire Stripper (18 Ga.)
- Z498 Wire Stripper (16 Ga.)
- Z499 Wire Stripper (14 Ga.)
- Z590 Wire Stripper (12 Ga.)
- Z591 Wire Stripper (10 Ga.)

The wire gage tooling is interchangeable if various wire gauges are required.

